

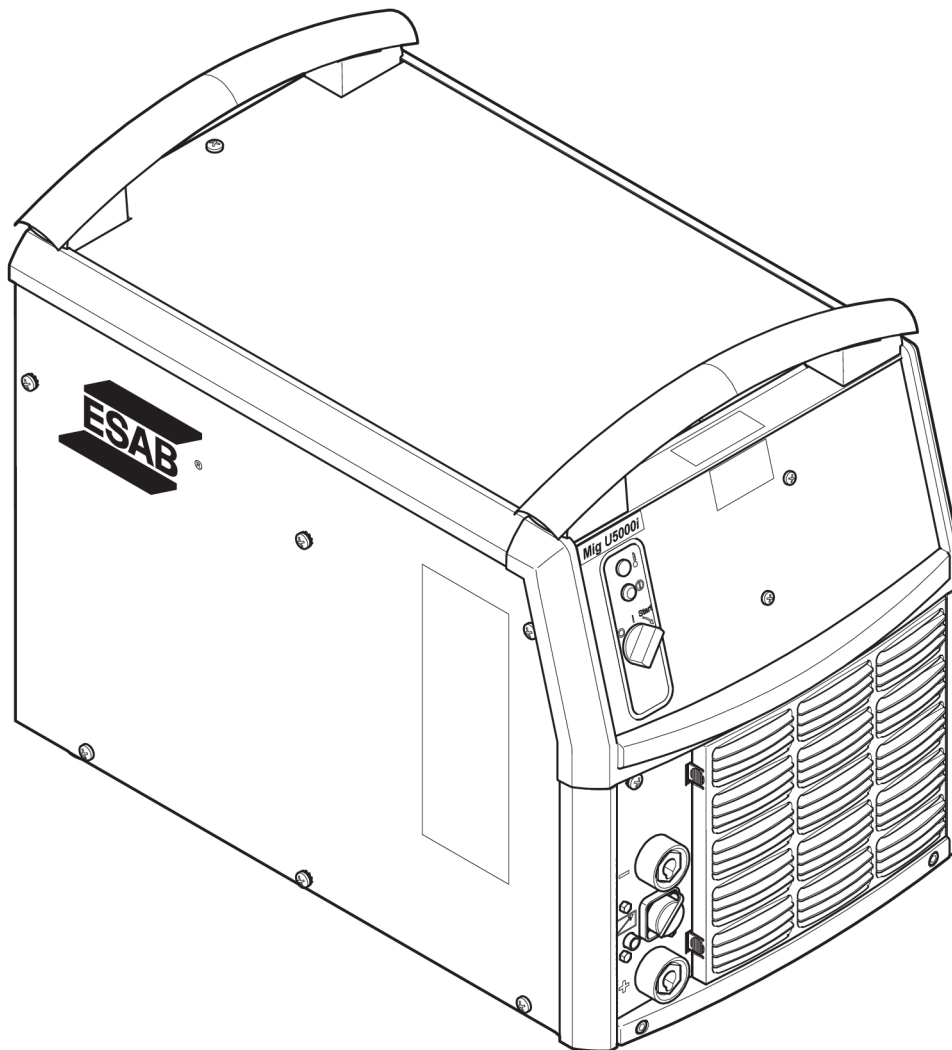

Aristo®

# *Mig 5000i*

460 V



## Instruction manual



## EU DECLARATION OF CONFORMITY

According to  
The Low Voltage Directive 2014/35/EU  
The EMC Directive 2014/30/EU  
The RoHS Directive 2011/65/EU

### Type of equipment

Welding power source

### Type designation

Mig 5000i/5000iw, 460V, valid from serial number 950 xxx xxxx  
Mig U5000i/U5000iw, 460V, valid from serial number 950 xxx xxxx

### Brand name or trademark

ESAB

### Manufacturer or his authorised representative established within the EEA

#### Name, address, and telephone No:

ESAB AB  
Lindholmsallén 9, Box 8004, SE-402 77 Göteborg, Sweden  
Phone: +46 31 50 90 00, [www.esab.com](http://www.esab.com)

### The following harmonised standard in force within the EEA has been used in the design:

EN 60974-1:2012, Arc welding equipment - Part 1: Welding power sources  
EN 60974-2:2013, Arc welding equipment - Part 2: Liquid cooling systems  
EN 60974-3:2014, Arc welding equipment - Part 3: Arc striking and stabilizing devices  
EN 60974-10:2014, Arc welding equipment - Part 10: Electromagnetic compatibility (EMC) requirements

### Additional Information:

Restrictive use, Class A equipment, intended for use in location other than residential  
Mig 5000i and U5000i are members of the ESAB Aristo® product family

**By signing this document, the undersigned declares as manufacturer, or the manufacturer's authorised representative established within the EEA, that the equipment in question complies with the safety requirements stated above.**

Date

Gothenburg, 2019-08-20

Signature

A handwritten signature in purple ink, appearing to read "Pedro Muniz". The signature is stylized and fluid.

Pedro Muniz  
Standard Equipment Director

CE 2019

<b>1</b>	<b>SAFETY</b> .....	<b>4</b>
1.1	Meaning of symbols .....	4
1.2	California Proposition 65 warning .....	4
1.3	Safety precautions .....	4
1.4	User responsibility .....	8
<b>2</b>	<b>INTRODUCTION</b> .....	<b>11</b>
2.1	Equipment .....	11
<b>3</b>	<b>TECHNICAL DATA</b> .....	<b>12</b>
<b>4</b>	<b>INSTALLATION</b> .....	<b>14</b>
4.1	Lifting instructions .....	14
4.2	Placing .....	14
4.3	Primary input .....	14
4.4	Terminating resistor .....	15
<b>5</b>	<b>OPERATION</b> .....	<b>16</b>
5.1	Connections and control devices .....	16
5.2	Turning on the power source .....	16
5.3	Fan control .....	17
5.4	Overheating protection .....	17
5.5	Remote control unit .....	17
<b>6</b>	<b>MAINTENANCE</b> .....	<b>18</b>
6.1	Cleaning the air filter .....	18
<b>7</b>	<b>TROUBLESHOOTING</b> .....	<b>19</b>
<b>8</b>	<b>ORDERING OF SPARE PARTS</b> .....	<b>20</b>
	<b>DIAGRAM</b> .....	<b>21</b>
	<b>ORDERING NUMBERS</b> .....	<b>22</b>
	<b>SPARE PARTS LIST</b> .....	<b>23</b>
	<b>ACCESSORIES</b> .....	<b>24</b>

# 1 SAFETY

## 1.1 Meaning of symbols

As used throughout this manual: Means Attention! Be Alert!



### DANGER!

Means immediate hazards which, if not avoided, will result in immediate, serious personal injury or loss of life.



### WARNING!

Means potential hazards which could result in personal injury or loss of life.



### CAUTION!

Means hazards which could result in minor personal injury.



### WARNING!

Before use, read and understand the instruction manual and follow all labels, employer's safety practices and Safety Data Sheets (SDSs).



## 1.2 California Proposition 65 warning



### WARNING!

Welding or cutting equipment produces fumes or gases which contain chemicals known in the State of California to cause birth defects and, in some cases, cancer. (California Health & Safety Code Section 25249.5 et seq.)



### WARNING!

This product can expose you to chemicals including lead, which are known to the state of California to cause cancer and birth defects or other reproductive harm. Wash hands after use.

For more information, go to [www.P65Warnings.ca.gov](http://www.P65Warnings.ca.gov).

## 1.3 Safety precautions



### WARNING!

These Safety Precautions are for your protection. They summarise precautionary information from the references listed in Additional Safety Information section. Before performing any installation or operating procedures, be sure to read and follow the safety precautions listed below as well as all other manuals, material safety data sheets, labels, etc. Failure to observe Safety Precautions can result in injury or death.



## PROTECT YOURSELF AND OTHERS

**Some welding, cutting and gouging processes are noisy and require ear protection. The arc, like the sun, emits ultraviolet (UV) and other radiation and can injure skin and eyes. Hot metal can cause burns. Training in the proper use of the processes and equipment is essential to prevent accidents. Therefore:**

1. Wear a welding helmet fitted with a proper shade of filter to protect your face and eyes when welding or watching.
2. Always wear safety glasses with side shields in any work area, even if welding helmets face shields and goggles are also required.
3. Use a face shield fitted with the correct filter and cover plates to protect your eyes, face, neck and ears from sparks and rays of the arc when operating or observing operations. Warn bystanders not to watch the arc and not to expose themselves to the rays of the electric-arc or hot metal.
4. Wear flameproof gauntlet type gloves, heavy long-sleeve shirt, cuff less trousers, high-topped shoes and a welding helmet or cap for protection, to protect against arc rays and hot sparks or hot metal. A flameproof apron may also be desirable as protection against radiated heat and sparks.
5. Hot sparks or metal can lodge in rolled up sleeves, trouser cuffs, or pockets. Sleeves and collars should be kept buttoned and open pockets eliminated from the front of clothing.
6. Protect other personnel from arc rays and hot sparks with a suitable non-flammable partition or curtains.
7. Use goggles over safety glasses when chipping slag or grinding. Chipped slag may be hot and can fly far. Bystanders should also wear goggles over safety glasses.



## FIRES AND EXPLOSIONS

**Heat from flames and arcs can start fires. Hot slag or sparks can also cause fires and explosions. Therefore:**

1. Protect yourself and others from flying sparks and hot metal.
2. Remove all combustible materials well away from the work area or cover the materials with a protective non-flammable covering. Combustible materials include wood, cloth, sawdust, liquid and gas fuels, solvents, paints and coatings paper, etc.
3. Hot sparks or hot metal can fall through cracks or crevices in floors or wall openings and cause a hidden smoldering fire or fires on the floor below. Make certain that such openings are protected from hot sparks and metal.
4. Do not weld, cut or perform other hot work until the work piece has been completely cleaned so that there are no substances on the work piece which might produce flammable or toxic vapors. Do not do hot work on closed containers, they may explode.
5. Have fire extinguishing equipment handy for instant use, such as a garden hose, water pail, sand bucket, or portable fire extinguisher. Be sure you are trained in its use.
6. Do not use equipment beyond its ratings. For example, an overloaded welding cable can overheat and create a fire hazard.
7. After completing operations, inspect the work area to make certain there are no hot sparks or hot metal which could cause a later fire. Use fire watchers when necessary.



## ELECTRICAL SHOCK

**Contact with live electrical parts and ground can cause severe injury or death. DO NOT use AC welding current in damp areas, if movement is confined, or if there is danger of falling. Therefore:**

1. Be sure the power source frame (chassis) is connected to the ground system of the input power.
2. Connect the workpiece to a good electrical ground.
3. Connect the work cable to the workpiece. A poor or missing connection can expose you or others to a fatal shock.
4. Use well-maintained equipment. Replace worn or damaged cables.
5. Keep everything dry, including clothing, work area, cables, torch/electrode holder and power source.
6. Make sure that all parts of your body are insulated from both the work piece and from the ground.
7. Do not stand directly on metal or the earth while working in tight quarters or a damp area; stand on dry boards or an insulating platform and wear rubber-soled shoes.
8. Put on dry, hole-free gloves before turning on the power.
9. Turn off the power before removing your gloves.
10. Refer to ANSI/ASC Standard Z49.1 for specific grounding recommendations. Do not mistake the work lead for a ground cable.



## ELECTRIC AND MAGNETIC FIELDS

**May be dangerous. Electric current flowing through any conductor causes localized Electric and Magnetic Fields (EMF). Welding and cutting current creates EMF around welding cables and welding machines. Therefore:**

1. Welders having pacemakers should consult their physician before welding. EMF may interfere with some pacemakers.
2. Exposure to EMF may have other health effects which are unknown.
3. Welders should use the following procedures to minimise exposure to EMF:
  - a) Route the electrode and work cables together. Secure them with tape when possible.
  - b) Never coil the torch or work cable around your body.
  - c) Do not place your body between the torch and work cables. Route cables on the same side of your body.
  - d) Connect the work cable to the workpiece as close as possible to the area being welded.
  - e) Keep welding power source and cables as far away from your body as possible.



## FUMES AND GASES

**Fumes and gases, can cause discomfort or harm, particularly in confined spaces. Shielding gases can cause asphyxiation. Therefore:**

1. Keep your head out of the fumes. Do not breathe the fumes and gases.
2. Always provide adequate ventilation in the work area by natural or mechanical means. Do not weld, cut or gouge on materials such as galvanized steel, stainless steel, copper, zinc, lead beryllium or cadmium unless positive mechanical ventilation is provided. Do not breathe fumes from these materials.

3. Do not operate near degreasing and spraying operations. The heat or arc can react with chlorinated hydrocarbon vapors to form phosgene, a highly toxic gas and other irritant gases.
4. If you develop momentary eye, nose or throat irritation while operating, this is an indication that ventilation is not adequate. Stop work and take necessary steps to improve ventilation in the work area. Do not continue to operate if physical discomfort persists.
5. Refer to ANSI/ASC Standard Z49.1 for specific ventilation recommendations.
6. **WARNING:** This product when used for welding or cutting, produces fumes or gases which contain chemicals known to the State of California to cause birth defects and in some cases cancer (California Health & Safety Code §25249.5 et seq.)



### **CYLINDER HANDLING**

**Cylinders, if mishandled, can rupture and violently release gas. A sudden rupture of cylinder valve or relief device can injure or kill. Therefore:**

1. Locate cylinders away from heat, sparks and flames. Never strike an arc on a cylinder.
2. Use the proper gas for the process and use the proper pressure reducing regulator designed to operate from the compressed gas cylinder. Do not use adaptors. Maintain hoses and fittings in good condition. Follow manufacturer's operating instructions for mounting regulator to a compressed gas cylinder.
3. Always secure cylinders in an upright position by chain or strap to suitable hand trucks, undercarriages, benches, wall, post or racks. Never secure cylinders to work tables or fixtures where they may become part of an electrical circuit.
4. When not in use, keep cylinder valves closed. Have valve protection cap in place if regulator is not connected. Secure and move cylinders by using suitable hand trucks.



### **MOVING PARTS**

**Moving parts, such as fans, rotors and belts can cause injury. Therefore:**

1. Keep all doors, panels, guards and covers closed and securely in place.
2. Stop engine or drive systems before installing or connecting unit.
3. Have only qualified people remove covers for maintenance and troubleshooting as necessary
4. To prevent accidental starting of equipment during service, disconnect negative (-) battery cable from battery.
5. Keep hands, hair, loose clothing and tools away from moving parts.
6. Reinstall panels or covers and close doors when service is finished and before starting engine.



### **WARNING!**

#### **FALLING EQUIPMENT CAN INJURE**

- Only use lifting eye to lift unit. Do NOT use running gear, gas cylinders or any other accessories.
- Use equipment of adequate capacity to lift and support unit.
- If using lift forks to move unit, be sure forks are long enough to extend beyond opposite side of unit.
- Keep cables and cords away from moving vehicles when working from an aerial location.



**WARNING!**  
**EQUIPMENT MAINTENANCE**

**Faulty or improperly maintained equipment can cause injury or death.**  
**Therefore:**

1. Always have qualified personnel perform the installation, troubleshooting and maintenance work. Do not perform any electrical work unless you are qualified to perform such work.
2. Before performing any maintenance work inside a power source, disconnect the power source from the incoming electrical power.
3. Maintain cables, earthing wire, connections, power cord and power supply in safe working order. Do not operate any equipment in faulty condition.
4. Do not abuse any equipment or accessories. Keep equipment away from heat sources such as furnaces, wet conditions such as water puddles, oil or grease, corrosive atmospheres and inclement weather.
5. Keep all safety devices and cabinet covers in position and in good repair.
6. Use equipment only for its intended purpose. Do not modify it in any manner.



**CAUTION!**  
**ADDITIONAL SAFETY INFORMATION**

**For more information on safe practices for electric arc welding and cutting equipment, ask your supplier for a copy of “Precautions and Safe Practices for Arc Welding, Cutting and Gouging”, Form 52-529.**

The following publications are recommended:

- ANSI/ASC Z49.1 - “Safety in Welding and Cutting”
- AWS C5.5 - “Recommended Practices for Gas Tungsten Arc Welding”
- AWS C5.6 - “Recommended Practices for Gas Metal Arc welding”
- AWS SP - “Safe practices” - Reprint, Welding Handbook
- ANSI/AWS F4.1 - “Recommended Safe Practices for Welding and Cutting of Containers That Have Held Hazardous Substances”
- OSHA 29 CFR 1910 - "Safety and health standards"
- CSA W117.2 - "Code for safety in welding and cutting"
- NFPA Standard 51B, “Fire Prevention During Welding, Cutting, and Other Hot Work”
- CGA Standard P-1, “Precautions for Safe Handling of Compressed Gases in Cylinders”
- ANSI Z87.1, "Occupational and Educational Personal Eye and Face Protection Devices"

## 1.4 User responsibility

Users of ESAB equipment have the ultimate responsibility for ensuring that anyone who works on or near the equipment observes all the relevant safety precautions. Safety precautions must meet the requirements that apply to this type of equipment. The following recommendations should be observed in addition to the standard regulations that apply to the workplace.

All work must be carried out by trained personnel well-acquainted with the operation of the equipment. Incorrect operation of the equipment may lead to hazardous situations which can result in injury to the operator and damage to the equipment.

1. Anyone who uses the equipment must be familiar with:
  - its operation
  - location of emergency stops
  - its function
  - relevant safety precautions
  - welding and cutting or other applicable operation of the equipment
2. The operator must ensure that:
  - no unauthorised person is stationed within the working area of the equipment when it is started up
  - no-one is unprotected when the arc is struck or work is started with the equipment
3. The workplace must:
  - be suitable for the purpose
  - be free from drafts
4. Personal safety equipment:
  - Always wear recommended personal safety equipment, such as safety glasses, flame-proof clothing, safety gloves
  - Do not wear loose-fitting items, such as scarves, bracelets, rings, etc., which could become trapped or cause burns
5. General precautions:
  - Make sure the return cable is connected securely
  - Work on high voltage equipment **may only be carried out by a qualified electrician**
  - Appropriate fire extinguishing equipment must be clearly marked and close at hand
  - Lubrication and maintenance must **not** be carried out on the equipment during operation



**WARNING!**

Arc welding and cutting can be injurious to yourself and others. Take precautions when welding and cutting.



**ELECTRIC SHOCK - Can kill**

- Install and ground the unit in accordance with instruction manual.
- Do not touch live electrical parts or electrodes with bare skin, wet gloves or wet clothing.
- Insulate yourself from work and ground.
- Ensure your working position is safe



**ELECTRIC AND MAGNETIC FIELDS - Can be dangerous to health**

- Welders having pacemakers should consult their physician before welding. EMF may interfere with some pacemakers.
- Exposure to EMF may have other health effects which are unknown.
- Welders should use the following procedures to minimize exposure to EMF:
  - Route the electrode and work cables together on the same side of your body. Secure them with tape when possible. Do not place your body between the torch and work cables. Never coil the torch or work cable around your body. Keep welding power source and cables as far away from your body as possible.
  - Connect the work cable to the workpiece as close as possible to the area being welded.



**FUMES AND GASES - Can be dangerous to health**

- Keep your head out of the fumes.
- Use ventilation, extraction at the arc, or both, to take fumes and gases away from your breathing zone and the general area.



**ARC RAYS - Can injure eyes and burn skin**

- Protect your eyes and body. Use the correct welding screen and filter lens and wear protective clothing.
- Protect bystanders with suitable screens or curtains.



**NOISE - Excessive noise can damage hearing**

Protect your ears. Use earmuffs or other hearing protection.



**MOVING PARTS - Can cause injuries**

- Keep all doors, panels and covers closed and securely in place. Have only qualified people remove covers for maintenance and troubleshooting as necessary. Reinstall panels or covers and close doors when service is finished and before starting engine.



- Stop engine before installing or connecting unit.
- Keep hands, hair, loose clothing and tools away from moving parts.



**FIRE HAZARD**

- Sparks (spatter) can cause fire. Make sure that there are no inflammable materials nearby.
- Do not use on closed containers.



**HOT SURFACE - Parts can burn**

- Do not touch parts bare handed.
- Allow cooling period before working on equipment.
- To handle hot parts, use proper tools and/or insulated welding gloves to prevent burns.

**MALFUNCTION - Call for expert assistance in the event of malfunction.**

**PROTECT YOURSELF AND OTHERS!**



**WARNING!**

Do not use the power source for thawing frozen pipes.



**CAUTION!**

This product is solely intended for arc welding.

**ESAB has an assortment of welding accessories and personal protection equipment for purchase. For ordering information contact your local ESAB dealer or visit us on our website.**

## 2 INTRODUCTION

---

The **Mig 5000i** is a GMAW (MIG/MAG) welding power source, which can also be used for SMAW (MMA) welding.

The manual is valid for:

- Mig 5000i

The power source is intended for use with the Aristo Feed 3004 or Aristo Feed 4004HD wire feed units for manual welding.

**ESAB accessories for the product can be found in the "ACCESSORIES" chapter of this manual.**

### 2.1 Equipment

The power source is supplied complete with terminating resistor, 5 m return cable and instruction manual.

### 3 TECHNICAL DATA

	<b>Mig 5000i</b>
<b>Mains voltage</b>	460 V $\pm$ 10%, 3~ 60 Hz
<b>Mains supply</b>	$S_{scmin}$ 14.54 MVA $Z^{max}$ 0.011 $\Omega$
<b>Primary current</b>	
$I^{max}$ GMAW (MIG/MAG)	37 A
$I^{max}$ GTAW (TIG)	30 A
$I^{max}$ SMAW (MMA)	38 A
<b>No-load power</b> demand when in the energy-saving mode, 6.5 min. after welding	
GTAW/GMAW (TIG/MIG)	36 W
SMAW (MMA)	43 W
<b>Voltage/current range</b>	
GMAW (MIG/MAG)	8 - 60 V / 16 - 500 A
GMAW (MIG/MAG), control panel M2	8 - 42 V
SMAW (MMA)	4 - 500 A
<b>Permissible load at GMAW (MIG/MAG)</b>	
60 % duty cycle	500 A / 39 V
100% duty cycle	400 A / 34 V
<b>Permissible load at TIG</b>	
60 % duty cycle	500 A / 30 V
100% duty cycle	400 A / 26 V
<b>Permissible load at SMAW (MMA)</b>	
60 % duty cycle	500 A / 40 V
100% duty cycle	400 A / 36 V
<b>Power factor</b> at maximum current ( $I^2$ ) SMAW/GTAW/GMAW (MMA/TIG/MIG)	0.90
<b>Efficiency</b> at maximum current ( $I^2$ )	
SMAW (MMA)	85 %
GTAW (TIG)	82 %
GMAW (MIG)	84 %
<b>Open-circuit voltage <math>U^0</math> max</b>	
GMAW (MIG/MAG) without VRD function <b>1)</b>	72 - 88 V
SMAW (MMA) without VRD function <b>1)</b>	68 - 80 V
GMAW (MIG/MAG), SMAW (MMA), VRD function deactivated <b>2)</b>	59 V
VRD function activated <b>2)</b>	< 35 V
<b>Operating temperature</b>	14 to 104 °F (-10 to +40 °C)
<b>Transport temperature</b>	-4 to 131 °F (-20 to +55 °C)

	<b>Mig 5000i</b>
<b>Dimensions l × w × h</b> without cooling unit	24.6 × 15.5 × 19.5 in. (625 × 394 × 496 mm)
with cooling unit	24.6 × 15.5 × 30.6 in. (625 × 394 × 776 mm)
<b>Continual A-weighted sound pressure</b>	<70 db
<b>Weight</b> without cooling unit	150 lb (68 kg)
with cooling unit	194 lb (88 kg)
<b>Insulation class</b> transformer	H
<b>Enclosure class</b>	IP23
<b>Application class</b>	S

<sup>1)</sup> Valid for power sources without VRD specification on the rating plate.

<sup>2)</sup> Valid for power sources with VRD specification on the rating plate. The VRD function is explained in the instruction manuals for the control panel, if the panel has that function.

### Duty cycle

The duty cycle refers to the time as a percentage of a ten-minute period that you can weld or cut at a certain load without overloading. The duty cycle is valid for 40 °C / 104 °F, or below.

### Enclosure class

The **IP** code indicates the enclosure class, i.e. the degree of protection against penetration by solid objects or water.

Equipment marked **IP23** is intended for indoor and outdoor use.

### Application class

The symbol S indicates that the power source is designed for use in areas with increased electrical hazard.

## 4 INSTALLATION

The installation must be carried out by a professional.



### NOTE!

#### Mains supply requirements

This equipment complies with IEC 61000-3-12 provided that the short-circuit power is greater than or equal to  $S^{scmin}$  at the interface point between the user's supply and the public system. It is the responsibility of the installer or user of the equipment to ensure, by consultation with the distribution network operator if necessary, that the equipment is connected only to a supply with a short-circuit power greater than or equal to  $S^{scmin}$ . Refer to the technical data in the TECHNICAL DATA chapter.

### 4.1 Lifting instructions

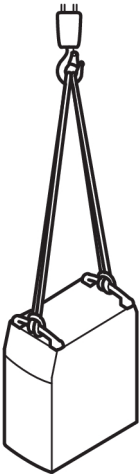
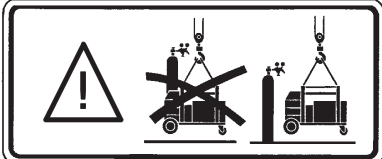
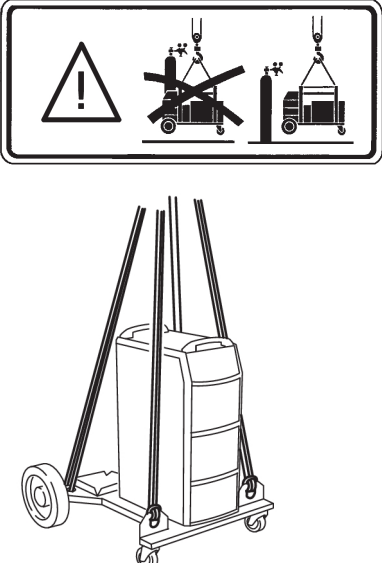
Power source	Trolley and power source	Trolley 2 and power source
		

### 4.2 Placing

Position the welding power source such that its cooling air inlets and outlets are not obstructed.

### 4.3 Primary input



#### WARNING!

ELECTRIC SHOCK CAN KILL! PRECAUTIONARY MEASURES SHOULD BE TAKEN TO PROVIDE MAXIMUM PROTECTION AGAINST ELECTRICAL SHOCK. BE SURE THAT ALL POWER IS OFF BY OPENING THE LINE (WALL) DISCONNECT SWITCH WHEN PRIMARY ELECTRICAL CONNECTIONS ARE MADE TO THE POWER SOURCE. BE SURE TO CHECK YOUR INPUT LEADS WITH A VOLTMETER TO MAKE SURE ALL POWER IS OFF.

Check that the unit is connected to the correct mains power supply voltage, and that it is protected by the correct fuse sizes.

A protective earth connection must be made, in accordance with regulations.

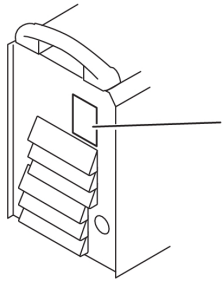

Rating plate with supply connection data

#### Recommended fuse sizes and minimum cable areas

Mig 5000i	460 V 3~ 60 Hz
<b>Mains voltage</b>	460 V
<b>Mains cable area, CU/AWG (mm<sup>2</sup>)</b>	4G6
<b>Phase current, I RMS</b>	28 A
<b>Fuse Time Delay</b>	50 A



#### NOTE!

Sizes per National Electric Code for 90 °C rated copper conductors @ 30 °C ambient. Not more than three conductors in raceway or cable. Local codes should be followed if they specify larger sizes other than those listed above.

## 4.4 Terminating resistor

In order to avoid communication interference, the ends of the CAN bus must be fitted with terminating resistors.

One end of the CAN bus is at the control panel, which has an integral terminating resistor. The other end at the power source must be fitted with the terminating resistor, as shown on the right.

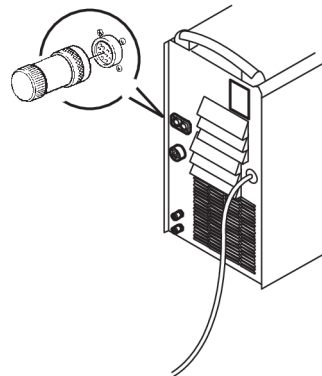

## 5 OPERATION

General safety regulations for handling the equipment can be found in the "SAFETY" chapter of this manual. Read it through before you start using the equipment!

### 5.1 Connections and control devices

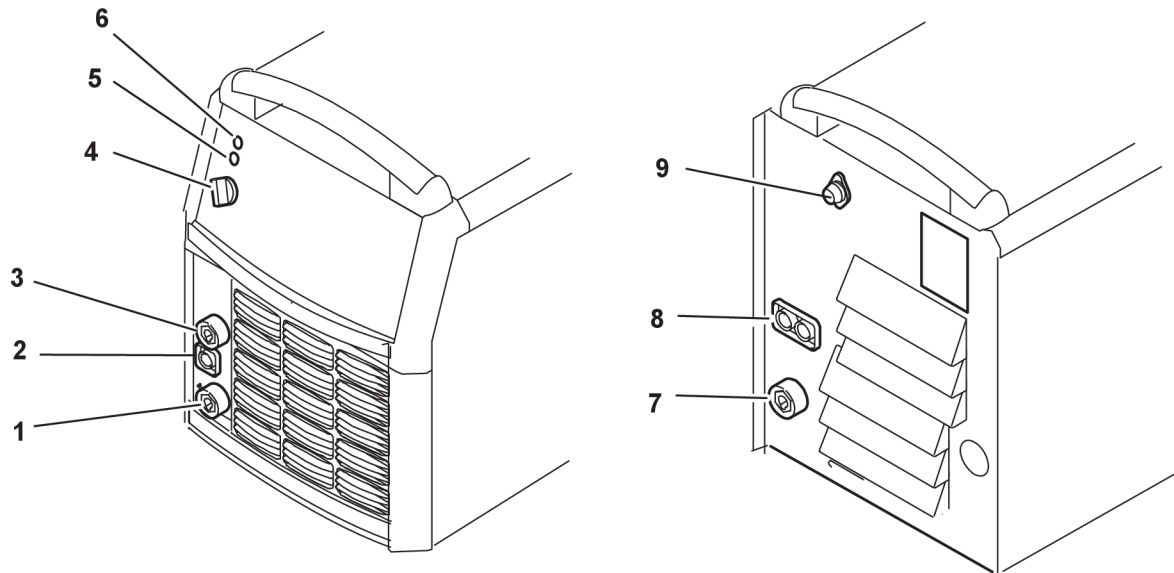

- |  |   |
|--|---|
| 1. Connection for welding current cable (+) (SMAW) | 6. Orange indicating lamp - Overheating   |
| 2. Connection for remote control                   | 7. Connection for welding current to the wire feed unit                               |
| 3. Connection for return cable (-)                 | 8. Connection for control cable to the wire feed unit or for the terminating resistor |
| 4. Main power supply switch, 0 / 1 / START         | 9. Fuse for supply voltage for feeder unit, 42 V                                      |
| 5. White indicating lamp - Power supply ON         |   |

### 5.2 Turning on the power source

Turn on the mains power by turning switch (3) to the "START" position. Release the switch, and it will return to the "1" position.

If the mains power supply should be interrupted while welding is in progress, and then be restored, the power source will remain de-energised until the switch is again turned manually to the "START" position.

Turn the unit off by turning the switch to the "0" position.

In the event of a loss of supply power or of turning the power source off in the normal manner, welding data will be stored so that it is available next time the unit is started.

### **5.3 Fan control**

The power source fans continue to run for 6.5 minutes after welding has stopped, and the unit switches to energy-saving mode. They start again when welding restarts.

The fans run at reduced speed for welding currents up to 180 A, and at full speed for higher currents.

### **5.4 Overheating protection**

The power source has three thermal overload trips which operate if the internal temperature becomes too high, interrupting the welding current and lighting the orange indicating lamp on the front of the unit. They reset automatically when the temperature has fallen.

### **5.5 Remote control unit**

The program version in U8 should be 1.20 or higher. Power sources with integral control panels should have program version 1.21 or higher, in order for the remote control to function correctly.

When the remote control unit is connected, the power source and wire feed unit are in remote control mode; the buttons and knobs are blocked. The functions can only be adjusted via the remote unit.

If the remote control unit is not to be used, the remote control unit must be disconnected from the power source / wire feed unit, as otherwise it will remain in remote control mode.

For more information about the operation of the remote control unit, see the operating instructions for the control panel.

## 6 MAINTENANCE

**NOTE!**

Regular maintenance is important for safe and reliable operation.

Only those persons who have appropriate electrical knowledge (authorised personnel) may remove the safety plates to connect or carry out service, maintenance or repair work on welding equipment.

**CAUTION!**

All warranty undertakings from the supplier cease to apply if the customer attempts any work to rectify any faults in the product during the warranty period.

### 6.1 Cleaning the air filter

1. Release the cover plate with the dust filter (1).
2. Swing out the cover plate (2).
3. Remove the dust filter (3).
4. Blow it clean with compressed air at reduced pressure.
5. Replace the filter with the finer mesh on the side against the cover plate (2).
6. Replace the cover plate with the filter.

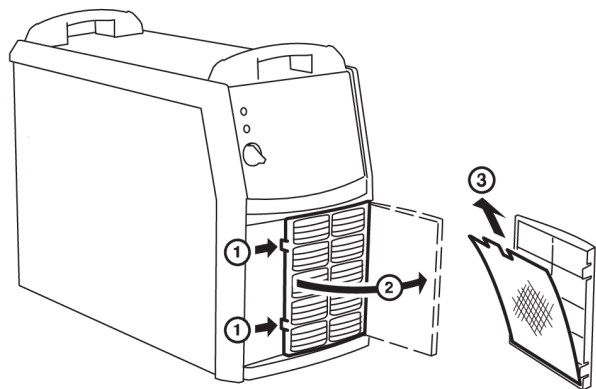

## 7 TROUBLESHOOTING

Try these recommended checks and inspections before sending for an authorised service technician.

Type of fault	Action
No arc.	<ul style="list-style-type: none"> <li>• Check that the mains power supply switch is turned on.</li> <li>• Check that the welding current supply and return cables are correctly connected.</li> <li>• Check that the correct current value is set.</li> </ul>
Welding current is interrupted during welding.	<ul style="list-style-type: none"> <li>• Check whether the thermal overload trips have operated (indicated by the orange lamp on the front panel).</li> <li>• Check the main power supply fuses.</li> </ul>
The thermal overload trips operate frequently.	<ul style="list-style-type: none"> <li>• Check to see whether the air filters are clogged.</li> <li>• Make sure that you are not exceeding the rated data for the power source (i.e. that the unit is not being overloaded).</li> </ul>
Poor welding performance.	<ul style="list-style-type: none"> <li>• Check that the welding current supply and return cables are correctly connected.</li> <li>• Check that the correct current value is set.</li> <li>• Check that the correct wire is being used.</li> <li>• Check the main power supply fuses.</li> </ul>

## 8 ORDERING OF SPARE PARTS

---

Mig 5000i is designed and tested in accordance with the international and European standards **IEC/EN 60974-1/-2** and **EN 60974-10**.

It is the obligation of the service unit which has carried out the service or repair work to make sure that the product still conforms to the mentioned standards.



**CAUTION!**

Repair and electrical work should be performed by an authorised ESAB service technician. Use only ESAB original spare and wear parts.

Spare parts and wear parts can be ordered through your nearest ESAB dealer, see [esab.com](https://www.esab.com). When ordering, please state product type, serial number, designation and spare part number in accordance with the spare parts list. This facilitates dispatch and ensures correct delivery.

# DIAGRAM

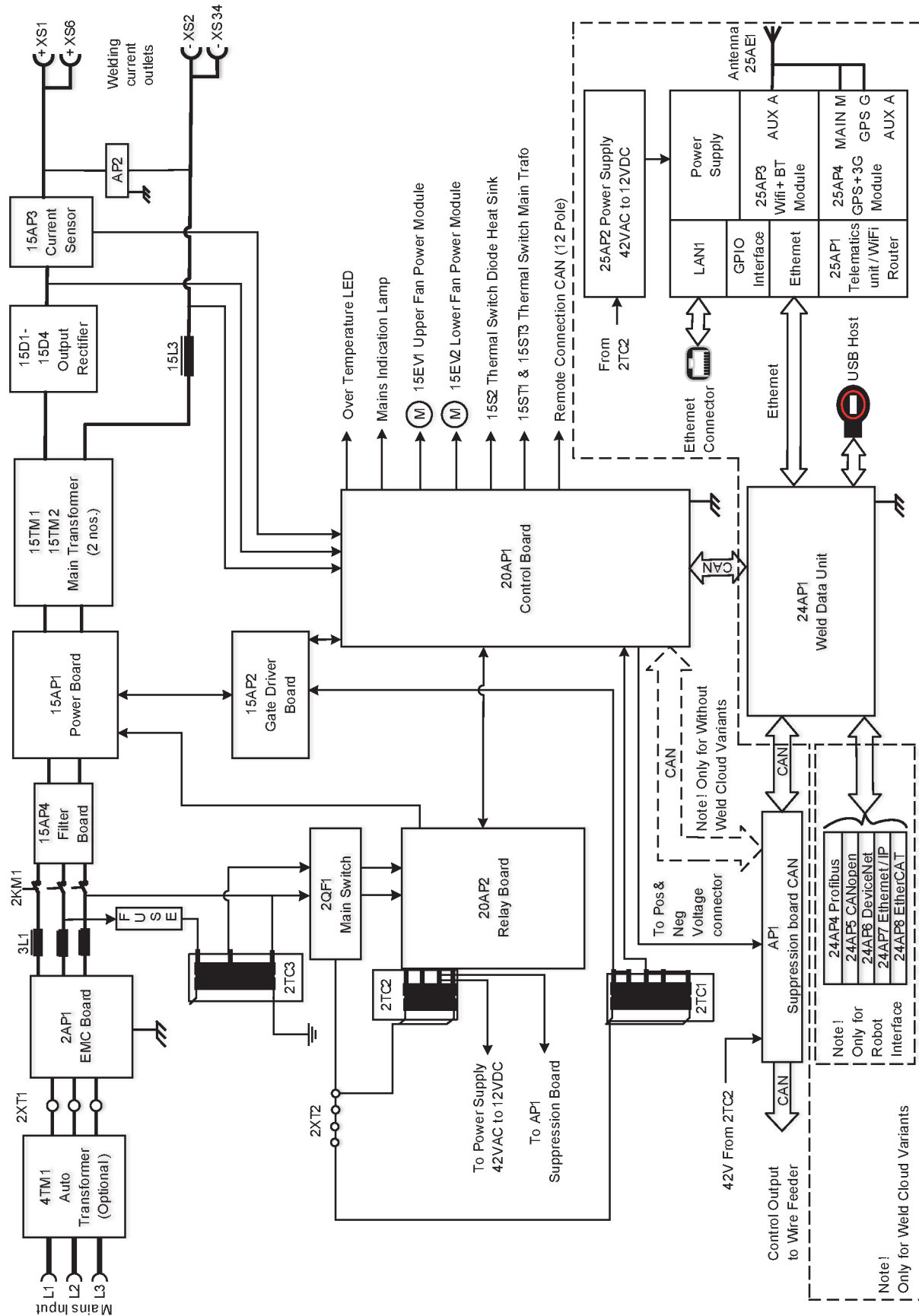

## ORDERING NUMBERS

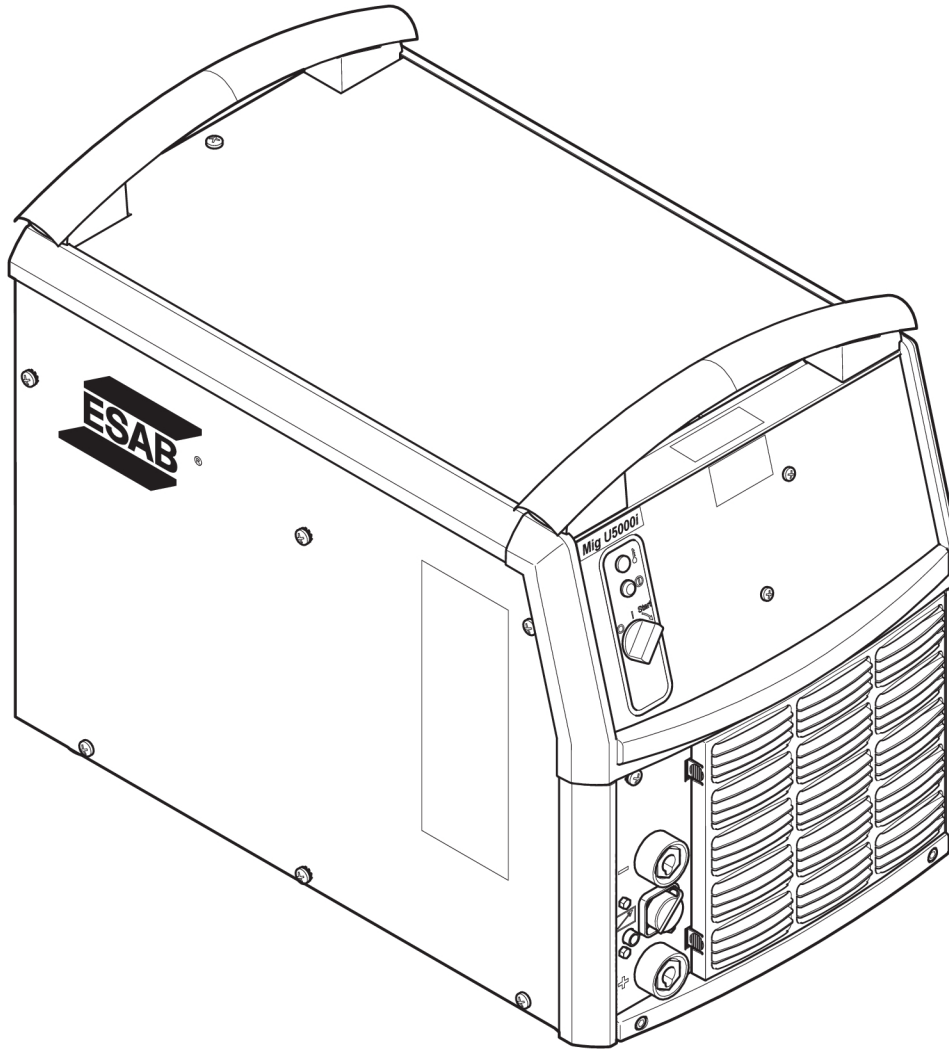

Ordering no.	Denomination	Product
0459 230 884	Welding power source	Mig 5000i
0459 839 020	Spare parts list	Mig 5000i, Mig U5000i, Mig 5000i WeldCloud™, Mig U5000i WeldCloud™

Technical documentation is available on the Internet at: [www.esab.com](http://www.esab.com)

## SPARE PARTS LIST

---



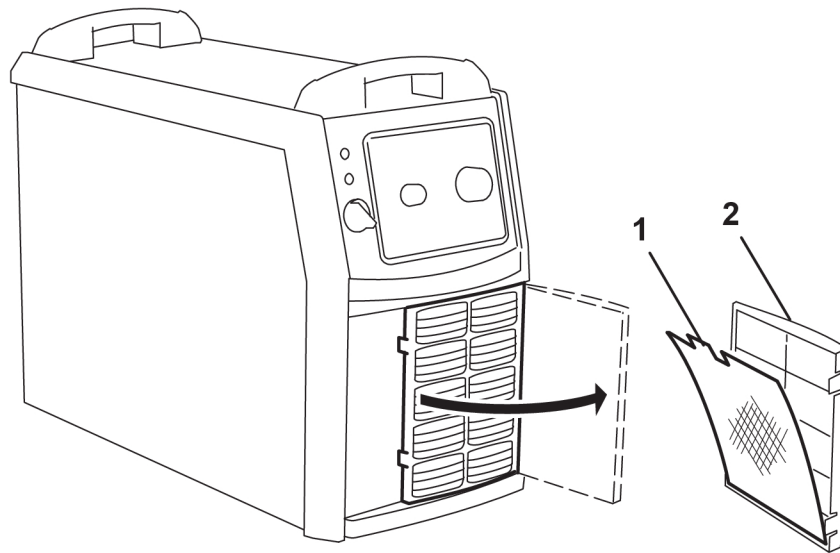

Item	Ordering no.	Denomination
1	0458 398 001	Filter
2	0458 383 991	Front grill



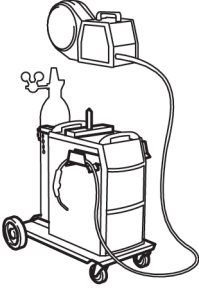
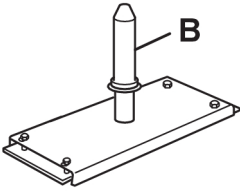
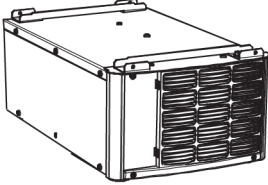

---



**ACCESSORIES**

---

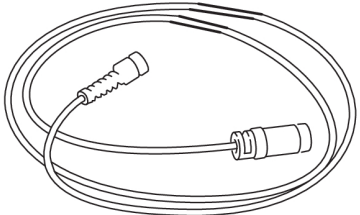
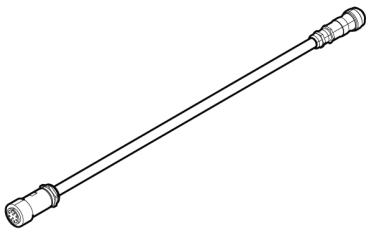
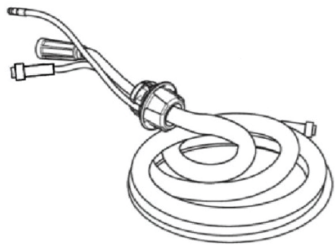
0458 530 880	<b>Trolley</b>	
0558 102 236	<b>HD Trolley 2-Cyl</b>	
0558 102 311	<b>Kit Bracket 4004i for HD Trolley</b>	
0458 731 880 0278 300 401	<b>Guide pin</b> <b>Insulating bushing (B), included in guide pin</b>	
0459 145 880	<b>Autotransformer TUA2</b>	
0459 491 910	<b>Remote control adapter RA12 12 pole</b> For analogue remote controls to CAN based equipment.	
0459 491 880	<b>Remote control unit MTA1 CAN</b> GMAW: wire feed speed and voltage SMAW: current and arc force GTAW: current, pulse and background current	
0459 491 882	<b>Remote control unit M1 10Prog CAN</b> Choice of one of 10 programs GMAW: voltage deviation GTAW and SMAW: current deviation	

0459 491 883	<b>Remote control unit AT1 CAN</b> SMAW and GTAW: current	
0459 491 884	<b>Remote control unit AT1 CF CAN</b> SMAW and GTAW: rough and fine setting of current.	
	<b>Remote control cable 4 pole - 12 pole</b>	
0459 554 884	0.25 m	
0459 554 880	5 m	
0459 554 881	10 m	
0459 554 882	15 m	
0459 554 883	25 m	
	<b>Adapter cable 10 pole - 12 pole</b>	
0446089880	0.5 m	
0446089881	1 m	
	<b>Connection set, 70 mm<sup>2</sup></b> 10 pole cable plug - 10 pole cable socket	
0459 528 780	1.7 m	
0459 528 781	5 m	
0459 528 782	10 m	
0459 528 783	15 m	
0459 528 784	25 m	
0459 528 785	35 m	
	<b>Connection set, 95 mm<sup>2</sup></b> 10 pole cable plug - 10 pole cable socket	
0459 528 980	1.7 m	

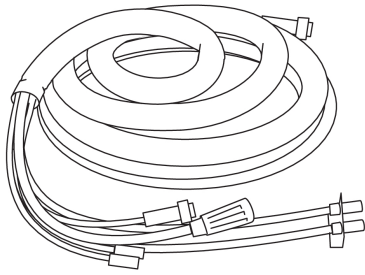
ACCESSORIES

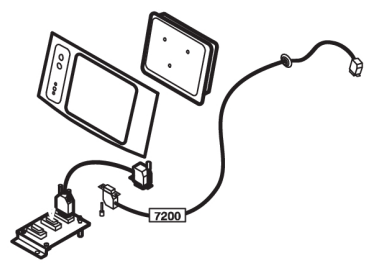
	<b>Connection set water, 70 mm<sup>2</sup></b> 10 pole cable plug - 10 pole cable socket	
0459 528 790	1.7 m	
0459 528 791	5 m	
0459 528 792	10 m	
0459 528 793	15 m	
0459 528 794	25 m	
0459 528 795	35 m	
	<b>Connection set water, 95 mm<sup>2</sup></b> 10 pole cable plug - 10 pole cable socket	
0459 528 990	1.7 m	
0459 528 991	5 m	
0459 528 992	7 m	
0459 528 993	15 m	
0459 528 994	25 m	
0700 006 897	<b>Return cable 5 m, 95 mm<sup>2</sup></b>	
0459 579 880	<b>MMC kit for power source Mig</b>	





# A WORLD OF PRODUCTS AND SOLUTIONS.



For contact information visit [esab.com](http://esab.com)

ESAB AB, Lindholmsallén 9, Box 8004, 402 77 Gothenburg, Sweden, Phone +46 (0) 31 50 90 00

[manuals.esab.com](http://manuals.esab.com)

